



iJRASET

International Journal For Research in
Applied Science and Engineering Technology



INTERNATIONAL JOURNAL FOR RESEARCH

IN APPLIED SCIENCE & ENGINEERING TECHNOLOGY

Volume: 11 Issue: VI Month of publication: June 2023

DOI:

www.ijraset.com

Call:  08813907089

E-mail ID: ijraset@gmail.com

A Laboratory Study of Use of Crumb Rubber as Partial Replacement of Fine Aggregate in Concrete

Amit Kumar Soren¹, Karan Kumar², Guptaeswari Muduli³, Sripriya Singh Dev⁴, Prof. Abhijit Mangaraj(Guide)⁵

Department of Civil Engineering, Gandhi Institute for Technology, (GIFT Autonomous), Bhubaneswar-752054

Abstract: *The aim of this study is to analyse the effect of addition of crumb rubber on the various properties of concrete. The crumb rubber is used as replacement over aggregates in the concrete mix. Crumb rubber is prepared from the scraps of tyres. In this study aggregates are replaced by 0%, 30%, 40%, 60%, 100% crumb rubber. The rubberized concrete is tested for slump and compression strength. It is found that the slump of rubberized concrete increases first but as the amount of rubber is increased the slump starts decreasing. It is observed that initial compression strength of rubberized concrete reduced significantly but the final strength is found to be more than that of ordinary concrete. Waste tyres cause tremendous pressure and ecological issues for the entire tyre industry when accumulated in cultivated land or combusted. Crumb rubber (<5 mm) grinded from waste tyres was introduced to substitute for natural fine aggregate in concrete and effectively solves the consumption challenge. This paper reviews the performance of concrete with crumb rubber as fine aggregate, providing evidence for crumb rubber concrete (CRC) materials design and application. Crumb rubber is characterized with light specific gravity, hydrophobicity and air entrapment in comparison with natural fine aggregate, inducing significant reduction in workability of fresh CRC and exhibiting poor bonding performance with cementitious matrix. By summarizing the compressive/tensile strength, elastic modulus and fracture behaviour of CRC at various rubber content, prediction models of strength reduction factors are proposed. The main reasons for strength deterioration are weak interface transition zone (ITZ) performance and non-uniform distribution of rubber particles. Water/chloride permeability, electrical/carbonation resistance and drying shrinkage of CRC are discussed for durability performance of CRC. Physical/chemical pre-treatments of rubber could alleviate the hydrophobicity and improve the mechanical and durability performance of transition zones between rubber and cement paste. Accordingly, scopes concerning the recycling of crumb rubber and its performance optimization are expected in future studies.*

Keywords: *concrete, crumb rubber, compression strength, slump.*

I. INTRODUCTION

A. General

In the present scenario the most dangerous environmental problem all around the world is disposal of the waste material. In some places people are using waste tire rubber as fuel but it is not eco-friendly (Bakri et al; 2004). However, some people treated the rubber as landfill in long period, but its non-bio degradable nature remains same. According to IARC (International Agency for Research of Cancer) the rubber is having chemicals which are carcinogenic which can cause cancer. Crumb rubber is recycled rubber which is produced from scraps tires. In the process of recycling the tyres, steel and tyre cords are removed and tyre rubber is separated. This process is done by cracker mill or mechanical means. The size of the crumb rubber depends on the use; it can be sized by passing through the screen according to the dimensions (Huang et al; 2004). Crumb rubber is also used in Astro Turf (as a top layer of grass in football ground). In an experimental study in 2008, it is tried to know about the mechanical properties of rubber based (Rubberized concrete). In this study ground rubber powder and crushed scrap tire rubber chips are used in concrete (Zheng et al; 2008). The result showed a big difference in properties of both the rubberized concretes. Compressive strength and modulus of elasticity of ground rubber based concrete was higher than the crushed rubber based concrete. Strength, workability and unit weight of rubberized concrete is reduced significantly (Khallo et al; 2008). According to the various studies undertaken on this research topic, it's a fact that if excess amount of rubber is mixed the strength will reduce which is not desirable. Every year, at an average of about 11,000,000 new vehicles are added to the Indian roads. Also, there is an increase of about 30,000,000 discarded tyres each year which pose a potential threat to the environment. Though, the tyres are being recycled yet there is a significant number of tyres added to the existing tire dumps or landfills. The generation of such waste tyres far exceeds than that which are now being recycle. Waste rubber tyres cause serious environment problems all around the globe. Thus, this accumulated waste material can be used for the civil engineering construction. Earlier studies have been performed on the use of worn out tyres in the asphalt mixes which were

found to be very promising. Although, not much attention has been given to the use of rubber (obtained from scrap tyres) in Portland cement concrete.

B. Materials And Methods

Rubberized concrete consists of aggregate chips as coarse aggregate, sand is use as fine aggregate and small rubber particles are used as a partial replacement of fine aggregate. The flexibility of the rubberized concrete is higher than the ordinary concrete. Because of the rubber which is mixed in the concrete it is called as rubberized Concrete. The amount of rubber should be very low in the rubberized concrete, because rubber has less strength and density than aggregate.



Fig:1.1 - Crumb rubber



Fig:1.2- Coarse aggregate



Fig:1.3- Sand (Fine aggregate)



Fig:1.4- Cement

C. Materials Used

- 1) COARCE AGGREGATES: 20 mm nominal size aggregates
- 2) FINE AGGREGATES
- 3) CEMENT: 43 grade cement
- 4) WATER: Portable clean water
- 5) TYRE CRUMB: The crumb rubber basically consists of particle size 0.075 mm.

The methods used to convert scrap (discarded) tyres into crumb rubber are (i) cracker mill process, (ii) granular process and (iii) micro mill process

D. Properties Of Rub Crete

In the early study it was found that coarse grading of rubber granules lowered the compressive strength of rubber mixtures more than fine grading. There was about 85% reduction in compressive strength and 50% reduction in tensile strength when the coarse aggregate was fully replaced by coarse rubber chips. However, it was observed that the specimen lost about 65% of their compressive strength and 50% of their tensile strength when the fine aggregate was fully replaced by fine crumb rubber. The more rough the rubber used in concrete mix the better the bonding developed between the surrounding matrix and the rubber particles which results in higher compressive strength. If somehow the bond between the surrounding cement paste and the rubber particles is improved then significantly higher compressive strength of rub concrete can be obtained.

E. Methodology

1) Construction Of Concrete Mixes

The concrete mixes are prepared so as to achieve target strength of 20N/mm² (i.e. M 20 concrete). The proportion used for concrete mixing is 1 : 1.5 : 3. The quantity of material used for construction of 36 cubes for each mix are tabulated below.

The concrete mixes are prepared varying amount of rubber from 1st 6 cubes group is being 0% replacement to the aggregate, 2nd 6 cubes group is being 30% replacement to the aggregate, 3rd 6 cubes group is being 60% replacement to the aggregate, 4th 6 cubes group is being 40% replacement to the aggregate, 5th 6 cubes group is being 50% replacement of aggregate & lastly the 6th 6cubes group is being 100% replacement of aggregate. The Rubberized Concrete Sand used for the experimental program was locally available material and conformed to Indian standard specifications IS 383-1970. Fine aggregate use was river sand. Coarse aggregate use was also bring from local benders, crumb rubber is also available in the local shop of waste tyres. The coarse aggregates are crushed with a maximum size of 20mm. the crumb rubber is well sieve by 75 micron sieve then for making a normal cube the material required for making M20 grade of cube are cement 1.47kg, sand as fine aggregate 2.20kg, metal chips as coarse aggregate 4.41kg the total weight of the material 8.08kg is used. When it's come to partial replacement of fine aggregate we can use the crumb rubber as the replacement material of sand by the calculation of volume of the sand. For 1st group of replacement we have to make 6 cubes of 0% replacement when we can use the metal chips as coarse aggregate, sand as fine aggregate, cement and the water cement will be 0.5. For a single mould the requirement of cement is 1.47kg and 5% addition will be needed that 0.0735kg then the total amount of cement is 1.54kg, then requirement of sand is 2.20kg and 5% addition will be necessary that is 0.11 after the addition the amount of sand is 2.31kg. for coarse aggregate 4.41kg and 5% will be addition that 0.22 after the addition 4.63kg of aggregate is needed for the mix for 1 mould for 6 moulds the amount of material required is cement 9.24kg, sand 13.86kg, coarse aggregate 27.78kg. Pour the all weight material in a tray and mix it well by the help of trowel and then add the required amount of water as 0.5 water cement ratio mix it for 5 to 7 minutes on the time of mixing prepare the mould with fixing the nut properly and oiling the whole mould by oil or grease oil and then pour it to the mould for 1/3 portion of mould and then tamp the mix by the help of tamping rod then full the other 1/3 part and repeat the process then continue the process one more time. Then settle the mix proper in the mould and keep it in a separate place for 24hours to settle it down

After 24 hours un mould the concrete cube by the help of renchy and submerge the block in to the water for next 24 hours.

Repeat the same procedure for the next 5 groups



Fig.1.5 - Mixing



Fig.1.6 – Concrete mix



Fig.1.7 - Tamping



Fig.1.8 – Mixture in moulds



Fig.1.9 – Concrete Blocks



Fig.1.10 - Curing

For 2nd group of replacement we have to make 6 cubes of 30% replacement when we can use the metal chips as coarse aggregate, sand as fine aggregate, cement and the water cement will be 0.5.

For a single mould the requirement of cement is 1.47kg and 5% addition will be needed that 0.0735kg then the total amount of cement is 1.54kg, then requirement of sand is 2.20kg and 5% addition will be necessary that is 0.11 after the addition the amount of sand is 2.31kg. for coarse aggregate 4.41kg and 5% will be addition that 0.22 after the addition 4.63kg of aggregate is needed for the mix for 1 mould for 6 moulds the amount of material required is cement 9.24kg, sand 13.86kg, coarse aggregate 27.78kg. for the 2nd group mix we have to replace 30% of the total fine aggregate as crumb rubber so calculate the 30% weight of the total sand required and pore it in a container then mark the level of amount sand volume covering the container then remove the sand from that container and pour the crumb rubber as per the marked volume of that container. The final weight of material used for mix is cement 9.24kg, sand 9.702kg, coarse aggregate 27.78kg, and crumb rubber will be measured as per volume of 4.158kg of sand.

Pour the all weight material in a tray and mix it well by the help of trowel and then add the required amount of water as 0.5 water cement ratio mix it for 5 to 7 minutes on the time of mixing prepare the mould with fixing the nut properly and oiling the whole mould by oil or grease oil and then pour it to the mould for 1/3 portion of mould and then tamp the mix by the help of tamping rod then full the other 1/3 part and repeat the process then continue the process one more time. Then settle the mix proper in the mould and keep it in a separate place for 24hours to settle it down

After 24 hours unmould the concrete cube by the help of renchy and submerge the block in to the water for next 24 hours.

For 3rd group of replacement we have to make 6 cubes of 60% replacement when we can use the metal chips as coarse aggregate, sand as fine aggregate, cement and the water cement will be 0.5.

For a single mould the requirement of cement is 1.47kg and 5% addition will be needed that 0.0735kg then the total amount of cement is 1.54kg, then requirement of sand is 2.20kg and 5% addition will be necessary that is 0.11 after the addition the amount of sand is 2.31kg. for coarse aggregate 4.41kg and 5% will be addition that 0.22 after the addition 4.63kg of aggregate is needed for the mix for 1 mould for 6 moulds the amount of material required is cement 9.24kg, sand 13.86kg, coarse aggregate 27.78kg. for the 3rd group mix we have to replace 60% of the total fine aggregate as crumb rubber so calculate the 60% weight of the total sand required and pore it in a container then mark the level of amount sand volume covering the container then remove the sand from that container and pour the crumb rubber as per the marked volume of that container. The final weight of material used for mix is cement 9.24kg, sand 5.544kg, coarse aggregate 27.78kg, and crumb rubber will be measured as per volume of 8.316kg of sand.

Pour the all weight material in a tray and mix it well by the help of trowel and then add the required amount of water as 0.5 water cement ratio mix it for 5 to 7 minutes on the time of mixing prepare the mould with fixing the nut properly and oiling the whole mould by oil or grease oil and then pour it to the mould for 1/3 portion of mould and then tamp the mix by the help of tamping rod then full the other 1/3 part and repeat the process then continue the process one more time. Then settle the mix proper in the mould and keep it in a separate place for 24hours to settle it down

After 24 hours unmould the concrete cube by the help of renchi and submerge the block in to the water for next 24 hours.

For 4th group of replacement we have to make 6 cubes of 40% replacement when we can use the metal chips as coarse aggregate, sand as fine aggregate, cement and the water cement will be 0.5.

For a single mould the requirement of cement is 1.47kg and 5% addition will be needed that 0.0735kg then the total amount of cement is 1.54kg, then requirement of sand is 2.20kg and 5% addition will be necessary that is 0.11 after the addition the amount of sand is 2.31kg. for coarse aggregate 4.41kg and 5% will be addition that 0.22 after the addition 4.63kg of aggregate is needed for the mix for 1 mould for 6 moulds the amount of material required is cement 9.24kg, sand 13.86kg, coarse aggregate 27.78kg. for the 4th group mix we have to replace 40% of the total fine aggregate as crumb rubber so calculate the 40% weight of the total sand required and pore it in a container then mark the level of amount sand volume covering the container then remove the sand from that container and pour the crumb rubber as per the marked volume of that container. The final weight of material used for mix is cement 9.24kg, sand 8.316kg, coarse aggregate 27.78kg, and crumb rubber will be measured as per volume of 5.544kg of sand.

Pour the all weight material in a tray and mix it well by the help of trowel and then add the required amount of water as 0.5 water cement ratio mix it for 5 to 7 minutes on the time of mixing prepare the mould with fixing the nut properly and oiling the whole mould by oil or grease oil and then pour it to the mould for 1/3 portion of mould and then tamp the mix by the help of tamping rod then full the other 1/3 part and repeat the process then continue the process one more time. Then settle the mix proper in the mould and keep it in a separate place for 24hours to settle it down

After 24 hours unmould the concrete cube by the help of renchi and submerge the block in to the water for next 24 hours.

For 5th group of replacement we have to make 6 cubes of 50% replacement when we can use the metal chips as coarse aggregate, sand as fine aggregate, cement and the water cement will be 0.5.

For a single mould the requirement of cement is 1.47kg and 5% addition will be needed that 0.0735kg then the total amount of cement is 1.54kg, then requirement of sand is 2.20kg and 5% addition will be necessary that is 0.11 after the addition the amount of sand is 2.31kg. for coarse aggregate 4.41kg and 5% will be addition that 0.22 after the addition 4.63kg of aggregate is needed for the mix for 1 mould for 6 moulds the amount of material required is cement 9.24kg, sand 13.86kg, coarse aggregate 27.78kg. for the 5th group mix we have to replace 50% of the total fine aggregate as crumb rubber so calculate the 50% weight of the total sand required and pore it in a container then mark the level of amount sand volume covering the container then remove the sand from that container and pour the crumb rubber as per the marked volume of that container.

The final weight of material used for mix is cement 9.24kg, sand 6.93kg, coarse aggregate 27.78kg, and crumb rubber will be measured as per volume of 6.93kg of sand.

Pour the all weight material in a tray and mix it well by the help of trowel and then add the required amount of water as 0.5 water cement ratio mix it for 5 to 7 minutes on the time of mixing prepare the mould with fixing the nut properly and oiling the whole mould by oil or grease oil and then pour it to the mould for 1/3 portion of mould and then tamp the mix by the help of tamping rod then full the other 1/3 part and repeat the process then continue the process one more time. Then settle the mix proper in the mould and keep it in a separate place for 24hours to settle it down

After 24 hours un mould the concrete cube by the help of renchi and submerge the block in to the water for next 24 hours.

For 6th group of replacement we have to make 6 cubes of 100% replacement when we can use the metal chips as coarse aggregate, sand as fine aggregate, cement and the water cement will be 0.5.

For a single mould the requirement of cement is 1.47kg and 5% addition will be needed that 0.0735kg then the total amount of cement is 1.54kg, then requirement of sand is 2.20kg and 5% addition will be necessary that is 0.11 after the addition the amount of sand is 2.31kg. for coarse aggregate 4.41kg and 5% will be addition that 0.22 after the addition 4.63kg of aggregate is needed for the mix for 1 mould for 6 moulds the amount of material required is cement 9.24kg, coarse aggregate 27.78kg. for the 6th group mix we have to replace 100% of the total fine aggregate as crumb rubber so calculate the 100% weight of the total sand required and pore it in a container then mark the level of amount sand volume covering the container then remove the sand from that container and pour the crumb rubber as per the marked volume of that container. The final weight of material used for mix is cement 9.24kg, sand will be completely replaced by crumb rubber, coarse aggregate 27.78kg, and crumb rubber will be measured as per volume of 13.86kg of sand.

Pour the all weight material in a tray and mix it well by the help of trowel and then add the required amount of water as 0.5 water cement ratio mix it for 5 to 7 minutes on the time of mixing prepare the mould with fixing the nut properly and oiling the whole mould by oil or grease oil and then pour it to the mould for 1/3 portion of mould and then tamp the mix by the help of tamping rod then full the other 1/3 part and repeat the process then continue the process one more time. Then settle the mix proper in the mould and keep it in a separate place for 24hours to settle it down

After 24 hours un mould the concrete cube by the help of renchi and submerge the block in to the water for next 24 hours.

II. REVIEW OF LITERATURE

- 1) Tushar R More, Pradip D Jadhao and SM Dumme: In their study the aim was to study of waste tyre as partial replacement of fine aggregate to produce rubberized concrete in M25 grade of mix. Different partial replacement of crumb rubber i.e., 0%, 3%, 6%, 9% and 12% by volume of fine aggregate are casted and tested for flexural strength and split tensile strength. The result shows that there is a reduction in all type of strength for crumb rubber mixture, but crumb rubber content concrete become more lean due to increase in partial replacement of crumb rubber as fine aggregate i.e., 3%, 6%, 9% and 12%. Flexural strength of concrete decreases with 3% replacement of sand and further decrease in strength with the increase in percentage of crumb rubber. For split tensile strength decreases with 3% replacement of sand and further decrease in strength with the increase in percentage of crumb rubber. This is mainly due to lower bond strength between cement paste and rubber tyre aggregate.
- 2) Prof. M. R. Wakchaura and Mr. Prashant. A. Charan : In this study they did partial replacement of fine aggregate as crumb rubber as 0.5%, 1%, 1.5% and 2% in M25 grade of concrete and its effects on concrete properties like compressive strength, flexural strength were investigated. Addition to this combination of glass fibre at ratio 0.4% and 0.5% addition to the weight of cement are used to regain the reduced strength due to use of waste tyre crumb rubber particle. Results indicate that replacement of waste tyre crumb rubber particle to the fine aggregate in concrete at ratio 0.5% and 1% there is no effect on the concrete properties would occur, but there was a considerable change for 1.5% and 2% replacement ratio.

- 3) Dr. B. Krishna Rao: In this investigation he did casting and testing of cubes, cylinders, and prisms for M20 grade of concrete and added 5% and 10% of rubber fibre by volume of concrete. There the specimens are tested for compression, split tensile and flexural strength. The test results were done and noted that due to addition of rubber fibre, strength of concrete decreases, but as observing ductility is improving. Hence it is used for medium grade of concrete. The various rubberised concrete mixes were designed in accordance with standard mix design procedure for normal concrete with grade of M20. As expected the target strength were not achieved for the mixes incorporating rubber fibre.
- 4) Er. YogenderAntil: The primary objective of their investigation is to study the strength behaviour i.e., compressive strength and flexural strength of rubberised concrete with different volume of crumb rubber. Parameter to be varied in Investigation is volume variation of crumb rubber. The proposed work is aimed to study the effect of volume variation of crumb rubber on the compressive strength, flexural strength and slump test. So they founded that strength of modified concrete is reduced with an increase in rubber content. The Flexural strength of the concrete decreases about 69% when 20% of sand is replaced by crumb rubber. The compressive strength of the concrete decreases about 37% when 20% of sand is replaced by crumb rubber. So overall large percentage of crumb rubber the lower the compressive strength and flexural strength as compared to conventional concrete.
- 5) Sulagno Banerjee, Aritra Mandal, Dr.Jessy: Robby The aim of their investigation was studies on mechanical properties of tyre rubber concrete. In their study they made a concrete of M25 grade by replacing 5%, 10%, 15%, 20% and 25% of tyre concrete with coarse aggregate and compared with regular M25 grade concrete. The properties of fresh concrete and flexural strength of hardened concrete were identified. So they concluded that flexural strength decreases in concrete. In 7 days' flexure strength, there is not much variation seen between conventional and rubberized concrete. So there was not much difference in strength of rubberized and conventional concrete.
- 6) Nithiya P and Portchejian G: In this research paper the mix design was done as per IS:10262-2009 to achieve the target strength. The concrete mixes were made by replacing fine aggregate with 5%, 10%, 15% and 20% for M20 grade concrete. So they founded that compressive strength decreases with the replacement of crumb rubber increased and 5% replacement of crumb rubber proves exceptionally well in compressive strength and tensile strength. It also gives more strength at 28th days for 5% replacement for M20 grade of cement and split tensile strength decreases at the maximum at the maximum of 25% when crumb rubber is replaced up to 10% of fine aggregate. Thus by replacing fine aggregate by crumb rubber safeguard the environment.
- 7) Jaylina Rana and Reshma Rughooputh: The broad aim of this work was to investigate the effects of partially substituted fine aggregate by rubber on the properties of fresh and hardened concrete. Different tests were performed to determine slump, compressive strength, tensile splitting strength, flexural and initial surface absorption of the concrete mixes. The compressive, tensile splitting strength, flexural decreases with increasing rubber content. Rubber fails the initial surface absorption test that is the surfaces of the concrete mixes are almost impermeable. However, partial replacement of fine aggregate with 5% of rubber can potentially be used in low strength concrete applications.
- 8) S. Selvakumar and R. Venkatakrishnaiah: They did concrete mix as per IS:10262-2009 for M30 grade of concrete for their investigation. The specimen was casted and used to determine the compressive strength, split tensile strength and flexural strength of concrete. They were tested for 7 and 28 days with replacement of fine aggregate with 5%, 10%, 15%, 20% of crumb rubber. Finally, they concluded that compressive strength of crumb rubber concrete with 5% replacement is 38.66 N/mm², it is higher than the strength of normal concrete i.e., 36.73 N/mm² on the 28 days. The compressive strength of crumb rubber concrete with 10% replacement it gives acceptable strength of 33.47 N/mm². In flexural strength of crumb rubber is lower than the strength of normal concrete and it was seen the same lowering of strength as compared to normal concrete in splitting tensile strength. So crumb rubber possess less bonding ability which effected on the strength of the concrete.
- 9) A Mansoor Ali and A. Sarvanan: This paper is the experimental study on waste rubber tire concrete. The mechanical and durability properties of concrete with composition of crumb rubber replacing part of the fine aggregate and cement with silica fumes were investigated for M25 grade as per IS:10262-2009. Compressive strength, flexural strength and split tensile strength was conducted for each sample by these authors. Finally they concluded that there was a reduction in compressive strength and split tensile strength and increase in flexural strength when the rubber content is increased. But the target strength was achieved by addition of silica fume and rubber in the concrete as compared to the addition of rubber without silica fumes. Therefore, this study has been focused on strength and durability requirement which shows that the concrete is sustainable and use for non-structural element where the low strength is required.

- 10) Kotresh K.M and Mesfin Getahun Belachew: In this present generation the disposal of waste tyres normally used in vehicle is becoming a serious issue for waste management problem in the world. It is estimated that 1.2 billion of waste tyre rubber produced globally per year. It is estimated that 11% of post-consumer tyres are exported and 27% are sent to landfill, stockpiled or dumped illegally when they have no use and only 4% is used for civil engineering projects. Hence major steps have been taken to find the potential application of waste tyre in civil engineering projects. In this investigation, our present study aims to investigate the optimal use of waste tyre rubber as coarse aggregate in concrete composite. A total of 24 cubes and 12 prisms are casted of M25 grade by replacing 10%, 20% and 30% of tyre aggregate as a coarse aggregate and compared with regular M25 grade concrete. Fresh and hardened concrete strength were identified. Finally, it was found that the strength was not achieved as targeted. But still it can be used for low strength structure as using crumb rubber can help in maintaining the environment.
- 11) Eldin and Senouci (2003), on the premise of experimental outcomes, demonstrated that there was around 85% reduction in compressive strength and half reduction in rigidity when the total coarse aggregate was completely replaced by coarse rubber chips. In any case, examples lost up to 65% of their compressive strength and up to half of their rubberity. He likewise demonstrated that when stacked in pressure examples carrying rubber did not show fragile disappointment. The continuous disappointment was watched, both of a part (coarse tire chips) or a shear mode (fine morsel rubber). It was contended that since the bond glue is significantly weaker in strain than in pressure the rubber treated example containing coarse tire chips would begin flopping in strain before it achieves its pressure confine. The produced pliable anxiety focuses at the top and base of the rubber totals result in numerous pliable small scale breaks that frame along the tried example. These smaller scale splits will quickly proliferate in the concrete glue. Until they experience and rubber total. On account of their capacity to withstand expansive pliable distortions, the rubber particles will go about as springs deferring the broadening of splits and anticipating whole crumbling of the concrete mass. The constant utilization of compressive load will cause an era of more splits and in addition augmenting of existing ones. Amid this procedure, the coming up short example is equipped for engrossing noteworthy plastic vitality and withstanding expansive miss happenings without full breaking down. This procedure will proceed until the burdens beat the bond between the concrete glue and the rubber totals .
- 12) Neil N. Eldin (2003) 2, broke down the after effects of compressive and part rigid qualities in rubber treated cement following 7 and 28 days curing and watched that there was slightest change in the compressive and rubber qualities between the 7th and 28th day, when the coarse total were supplanted by rubber chips with an expansive volume that is for the examples carrying 75% and 100% tire chips. The decrease of up to 85% of compressive and half of rubberity has been observed when the coarse total was supplanted by rubber. A little decrease was observed when sand was supplanted with piece rubber. The examples showed high limit with regards to retaining plastic vitality under both pressure and strain loadings .
- 13) Topcu (1995) 3, investigated the consequences of pressure tests led on normal and rubber treated concrete. He also observed that the compressive strength of standard cement gotten from 3D shape tests is higher than that acquired from barrel tests. In any case, the outcomes regarding rubber treated cements out of the blue demonstrated the turn around. This shows the mechanical strength of rubber treated mixture is extraordinarily influenced with the size, extent, surface of rubber particles and the sort of concrete utilized as a part of such mixture.
- 14) Goulias and Ali (1997) 9, on premise of test outcomes utilizing diverse parameters, it was discovered that dynamic moduli of flexibility and inflexibility diminished with an expansion of the rubber substance, demonstrating that a less concrete and less fragile material was acquired. The damping limit of cement (a measure of the capacity of the material to diminish the adequacy of free vibrations in its body) appeared to diminish with an expansion of the rubber substance.
- 15) On the other hand, Topcu and Avcular (1997a) and Fatuhi and Clark (1996) suggested utilizing rubber treated cements in conditions where vibration damping is required, for example, in structures as a tremor stun wave safeguard, in establishment cushions for apparatus, and in railroad stations. After effects of Poisson's proportion estimations showed that barrels with 20% rubber had a bigger proportion of horizontal strain to the comparing pivotal strain than that of 30% rubber concrete chambers (Goulias and Ali 1997a). It was additionally discovered (Goulias and Ali 1997) that the higher the rubber substance, the higher the proportion of dynamic modulus of flexibility to the static modulus of versatility. The dynamic modulus was then found with compressive strength, giving a high level of relationship between's the two parameters. This recommends nondestructive estimations of the dynamic modulus of versatility might be utilized for evaluating the compressive strength of rubber treated. A decent relationship between's compressive strength and the damping coefficient figured from transverse recurrence was additionally discovered, demonstrating that the damping coefficient of rubber treated may moreover be utilized for anticipating the compressive strength [20]. Consequently more research is required before such suggestions can be made.

16) Topcu and Ozclikors (1991) demonstrate that 10% rubber chips expansion expanded the strength of cement by 23%. They likewise researched the workability of rubber treated mixture. They watched a reduction in droop with expanded rubber substance by aggregate total volume. Their outcomes demonstrated that at rubber substances of 40% by aggregate total volume, the droop was close to 0 and the concrete was not workable by hand. Such type of mixture must be compacted utilizing a mechanical vibrator. Mixture containing fine piece rubber was, in any case, more workable than mixture containing either coarse tire chips or morsel rubber or a mix of them.

III. EXPERIMENTAL INVESTIGATIONS

The compressive strength of the concrete cube test provides an idea about all the characteristics of concrete. By this single test one judge that whether Concreting has been done properly or not. Concrete compressive strength for general construction varies from 15 MPa (2200 psi) to 30 MPa (4400 psi) and higher in commercial and industrial structures.

Compressive strength of concrete depends on many factors such as water-cement ratio, cement strength, quality of concrete material, quality control during the production of concrete, etc.

Test for compressive strength is carried out either on a cube or cylinder. Various standard codes recommend a concrete cylinder or concrete cube as the standard specimen for the test. American Society for Testing Materials ASTM C39/C39M provides Standard Test Method for Compressive Strength of Cylindrical Concrete Specimens.

A. Compressive Strength Definition

Compressive strength is the ability of material or structure to carry the loads on its surface without any crack or deflection. A material under compression tends to reduce the size, while in tension, size elongates.

1) Compressive Strength Formula

Compressive strength formula for any material is the load applied at the point of failure to the cross-section area of the face on which load was applied.

Compressive Strength = Load / Cross-sectional Area

Procedure: Compressive Strength Test of Concrete Cubes

For cube test two types of specimens either cubes of 15cm X 15cm X 15cm or 10cm X 10cm x 10cm depending upon the size of aggregate are used. For most of the works cubical molds of size 15cm x 15cm x 15cm are commonly used.

This concrete is poured in the mold and appropriately tempered so as not to have any voids. After 24 hours, molds are removed, and test specimens are put in water for curing. The top surface of these specimen should be made even and smooth. This is done by placing cement paste and spreading smoothly on the whole area of the specimen.

These specimens are tested by compression testing machine after seven days curing or 28 days curing. Load should be applied gradually at the rate of 140 kg/cm² per minute till the Specimens fails. Load at the failure divided by area of specimen gives the compressive strength of concrete.

Following are the procedure for testing the Compressive strength of Concrete Cubes

Apparatus for Concrete Cube Test

Compression testing machine

Preparation of Concrete Cube Specimen

The proportion and material for making these test specimens are from the same concrete used in the field.

Specimen

6 cubes of 15 cm size Mix. M15 or above

Mixing of Concrete for Cube Test

Mix the concrete either by hand or in a laboratory batch mixer



Fig: 3.1- Mould

2) *Hand Mixing*

1. Mix the cement and fine aggregate on a watertight none-absorbent platform until the mixture is thoroughly blended and is of uniform color.
2. Add the coarse aggregate and mix with cement and fine aggregate until the coarse aggregate is uniformly distributed throughout the batch.
3. Add water and mix it until the concrete appears to be homogeneous and of the desired consistency.

3) *Sampling of Cubes for Test*

1. Clean the moulds and apply oil.
2. Fill the concrete in the moulds in layers approximately 5 cm thick.
3. Compact each layer with not less than 35 strokes per layer using a tamping rod (steel bar 16mm diameter and 60cm long, bullet-pointed at lower end).
4. Level the top surface and smoothen it with a trowel.

4) *Curing of Cubes*

The test specimens are stored in moist air for 24 hours and after this period the specimens are marked and removed from the moulds and kept submerged in clear freshwater until taken out prior to the test.

5) *Precautions for Tests*

The water for curing should be tested every 7 days and the temperature of the water must be at 27±2°C.

Procedure for Concrete Cube Test

1. Remove the specimen from the water after specified curing time and wipe out excess water from the surface.
2. Take the dimension of the specimen to the nearest 0.2m
3. Clean the bearing surface of the testing machine
4. Place the specimen in the machine in such a manner that the load shall be applied to the opposite sides of the cube cast.
5. Align the specimen centrally on the base plate of the machine.
6. Rotate the movable portion gently by hand so that it touches the top surface of the specimen.
7. Apply the load gradually without shock and continuously at the rate of 140 kg/cm²/minute till the specimen fails
8. Record the maximum load and note any unusual features in the type of failure.

Note: Minimum three specimens should be tested at each selected age. If the strength of any specimen varies by more than 15% of average strength, the results of such specimens should be rejected. The average of three specimens gives the crushing strength of concrete. The strength requirements of concrete.

6) *Calculations of Compressive Strength*

Size of the cube = 15cm x 15cm x 15cm

Area of the specimen (calculated from the mean size of the specimen) = 225 cm²

Characteristic compressive strength (f_{ck}) at 7 days =

Expected maximum load = f_{ck} x area x f.s

Range to be selected is.....

Similar calculation should be done for 28 day compressive strength

Maximum load applied =tonnes =N

Compressive strength = (Load in N/ Area in mm²) =N/mm²

=N/mm²

7) *Results of Concrete Cube Test*

Average compressive strength of the concrete cube =N/ mm² (at 7 days)

Average compressive strength of the concrete cube = N/mm² (at 28 days)

8) *Reports of Cube Test*

1. Identification mark
2. Date of test
3. Age of specimen
4. Curing conditions, including date of manufacture of specimen
5. Appearance of fractured faces of concrete and the type of fracture if they are unusual

9) *Compressive Strength of Concrete at Various Ages*

The strength of concrete increases with age. The table shows the strength of concrete at different ages in comparison with the strength at 28 days after casting.

Age	Strength percent
1 day	16%
3 days	40%
7 days	65%
14 days	90%
28 days	99%

Compressive Strength of Different Grades of Concrete

% of partial replacement of concrete of grade M20	Minimum compressive strength N/mm ²		
	7days	14days	28days
100% sand – 0% crumb rubber	12.97 N/mm ²	18 N/mm ²	20 N/mm ²
70% sand – 30% crumb rubber	10 N/mm ²	12.5 N/mm ²	16.75 N/mm ²
40% sand – 60% crumb rubber	7.24 N/mm ²	9.85 N/mm ²	11.7 N/mm ²
40% sand – 60% crumb rubber	9.2 N/mm ²	14.5 N/mm ²	19.88 N/mm ²
50% sand – 50% crumb rubber	8.35 N/mm ²	11.88 N/mm ²	13.85 N/mm ²
0% sand – 100% crumb rubber	6.3 N/mm ²	8 N/mm ²	9.86 N/mm ²

% of partial replacement of concrete of grade M20	Specified characteristic compressive strength (N/mm ²)		
	7days	14days	28days
100% sand – 0% crumb rubber	292 N/mm ²	403 N/mm ²	450 N/mm ²
70% sand – 30% crumb rubber	45.25 N/mm ²	60 N/mm ²	70 N/mm ²
40% sand – 60% crumb rubber	104.5 N/mm ²	145 N/mm ²	160 N/mm ²
40% sand – 60% crumb rubber	188 N/mm ²	260 N/mm ²	290 N/mm ²
50% sand – 50% crumb rubber	143.5 N/mm ²	195 N/mm ²	220 N/mm ²
0% sand – 100% crumb rubber	97.53 N/mm ²	133 N/mm ²	150 N/mm ²

B. Flexural Test of Concrete

Flexural test on concrete based on the ASTM standards are explained. Differences if present in specification or any other aspects of flexural test on concrete between ASTM standard, Indian standard, and British standard are specified.

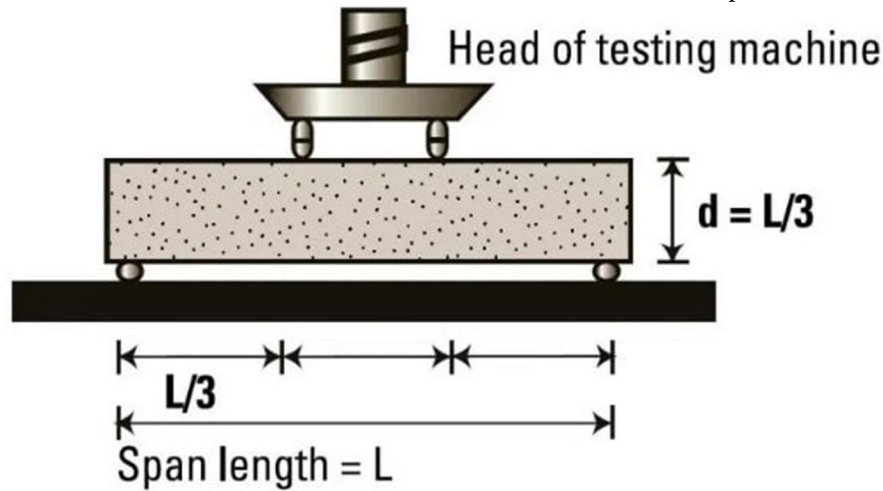

Fig.3.2: Flexural Test on Concrete (Three Point Loading Test)

Following topics regarding flexural tests on concrete is discussed:

- What is flexural test on concrete?
- What is the application of flexural test on concrete?
- What are the factors that cause variability in flexural test results?
- Size of concrete specimen for flexural test
- Apparatus required for flexural test on concrete
- Sample preparation
- Test procedure
- Computation of modulus of rupture

1) What is Flexural Test on Concrete?

Flexural test evaluates the tensile strength of concrete indirectly. It tests the ability of unreinforced concrete beam or slab to withstand failure in bending. The results of flexural test on concrete expressed as a modulus of rupture which denotes as (*MR*) in MPa or psi. The flexural test on concrete can be conducted using either three point load test (ASTM C78) or center point load test (ASTM C293). The configuration of each test is shown in Figure-2 and Figure-3, respectively. Test method described in this article is according to ASTM C78.

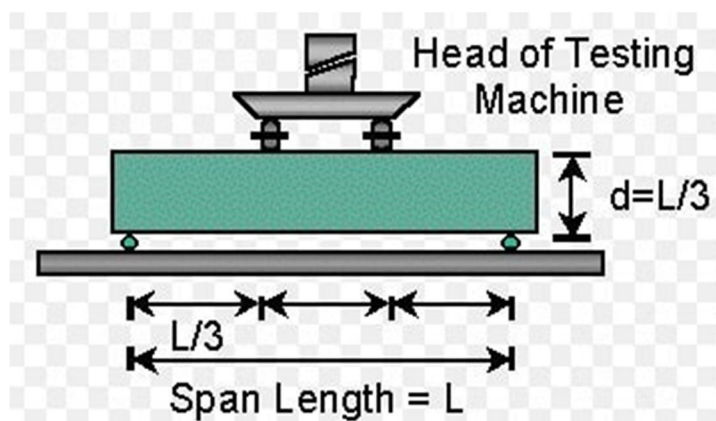

Fig.3.3: Three-Point Load Test (ASTM C78)

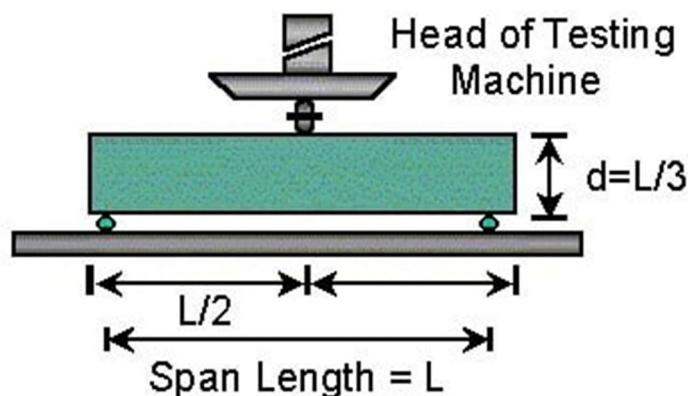

Fig.3.4 Center Point Load Test (ASTM C293)

It should be noticed that, the modulus of rupture value obtained by center point load test arrangement is smaller than three-point load test configuration by around 15 percent. Moreover, it is observed that low modulus of rupture is achieved when larger size concrete specimen is considered. Furthermore, modulus of rupture is about 10 to 15 percent of compressive strength of concrete. It is influenced by mixture proportions, size and coarse aggregate volume used for specimen construction. Finally, the following equation can be used to compute modulus of rupture, but it must be determined through laboratory test if it is significant for the

design: **Where** $f_r = 7.5\sqrt{f'_c}$ → Equation-1 : f_r : Modulus of rupture f'_c : concrete compressive strength



Fig.3.5: Flexural Test Machine and Concrete Specimen (ASTM C78)

2) What are the Applications of Flexural Test on Concrete?

Following are the applications of flexural test:

- Specifying compliance with standards
- It is an essential requirement for concrete mix design
- It is employed in testing concrete for slab and pavement construction

3) *What Factors Cause Variability in Flexural Test Results?*

- Concrete specimen preparation
- Specimen size
- Moisture condition of the concrete specimen
- Curing of the concrete specimen
- And whether the specimen is molded or sawed to the required size

4) *Size of Concrete Specimen for Flexural Test*

According to ASTM the size of the specimen is 150mm width, 150mm depth and the length should not be at least three times the depth of the specimen. Indian standard determined the size of the concrete specimen as 150mm width, 150mm depth, and span of 700mm. It also states that a size of 100mm width, 100mm depth, and span of 500mm can be used if the maximum aggregate size used is not greater than 19mm. British standard specifies square specimen cross section with 100mm or 150mm dimension and the span ranges from four to five times specimen depth. However, it preferred 150mm width, 150mm depth, and span of 750mm for the specimen.

5) *Apparatus for Flexural Test on Concrete*

- Steel, iron cast, or other nonabsorbent material molds with size of (150mmX150mmX 750mm)
- Tamping rods: ASTM specify large rode (16mm diameter and 600mm long) and small rode (10mm diameter and 300mm long)
- Testing machine capable of applying loads at a uniform rate without interruption of shocks
- Scoop
- Trowel
- Balance with accuracy of 1g
- Power driven concrete mixer
- Table vibration in the case of using vibration to compact concrete in molds

6) *Sample Preparation of Concrete*

- Determine proportions of materials including cement, sand, aggregate and water.
- Mix the materials using either by hand or using suitable mixing machine in batches with size of 10 percent greater than molding test specimen.
- Measure the slump of each concrete batch after blending.
- Place molds on horizontal surface and lubricate inside surface with proper lubricant material and excessive lubrication should be prevented.
- Pour fresh concrete into the molds in three layers.
- Compact each layer with 16mm rode and apply 25 strokes for each layer or fill the mold completely and compact concrete using vibration table.
- Remove excess concrete from the top of the mold and smoothen it without imposing pressure on it.
- Cover top of specimens in the molds and store them in a temperature room for 24 hours.
- Remove the molds and moist cure specimens at $23\pm 2^{\circ}\text{C}$ till the time of testing.
- The age of the test is 14 days and 28 days and three specimens for each test should be prepared (according to Indian Code, the specimen is stored in water at $24\text{-}30^{\circ}\text{C}$ for 48hours and then tested)

7) *Procedure of Flexural Test on Concrete*

- The test should be conducted on the specimen immediately after taken out of the curing condition so as to prevent surface drying which decline flexural strength.
- Place the specimen on the loading points. The hand finished surface of the specimen should not be in contact with loading points. This will ensure an acceptable contact between the specimen and loading points.
- Center the loading system in relation to the applied force.
- Bring the block applying force in contact with the specimen surface at the loading points.

- Applying loads between 2 to 6 percent of the computed ultimate load.
- Employing 0.10 mm and 0.38 mm leaf-type feeler gages, specify whether any space between the specimen and the load-applying or support blocks is greater or less than each of the gages over a length of 25 mm or more.
- Eliminate any gap greater than 0.10mm using leather shims (6.4mm thick and 25 to 50mm long) and it should extend the full width of the specimen.
- Capping or grinding should be considered to remove gaps in excess of 0.38mm.
- Load the specimen continuously without shock till the point of failure at a constant rate (Indian standard specified loading rate of 400 Kg/min for 150mm specimen and 180kg/min for 100mm specimen, stress increase rate 0.06+/-0.04N/mm².s according to British standard).
- The loading rate as per ASTM standard can be computed based on the following equation:

$$r = \frac{Sbd^2}{L} \rightarrow \text{Equation-2}$$

Where: *r*: loading rate *S*: rate of increase of extreme fiber *b*: average specimen width *d*: average specimen depth *L*: span length

- Finally, measure the cross section of the tested specimen at each end and at center to calculate average depth and height.

8) Computation of Modulus of Rupture

The following expression is used for estimation of modulus of rupture:

$$MR = \frac{3PL}{2bd^2} \rightarrow \text{Equation-3}$$

Where: *MR*: modulus of rupture *P*: ultimate applied load indicated by testing machine *L*: span length *b*: average width of the specimen at the fracture *d*: average depth of the specimen at the fracture Read More: [Compressive Strength of Concrete -Cube Test, Procedure, Results](#) [Why do We Test Concrete Compressive Strength after 28 Days?](#) [Tests for Workability of Concrete at Construction Site and Recommended Values](#) [Tests on Cement at Construction Site to Check Quality of Cement](#) [Testing of Sand Quality at Construction Site for Concrete](#) [Concrete Slump Test for Workability -Procedure and Results](#)

The water absorption test determines the water absorption rate (sorptivity) of both the outer and inner concrete surfaces. The test involves the measurement of the increase of mass of concrete samples resulting from the absorption of water as a function of time when only one face of the specimen is exposed to water.

The concrete specimens are either taken from drilled cores or molded in cylinders. The samples should be saturated and weighted before the test. The absorption can be estimated at different distances from the exposed surface.

Factors Influencing Water Absorption of Concrete

- Concrete mix proportions.
- Chemical admixtures and supplementary cementitious materials in the concrete.
- Composition and physical properties of the cementitious component and the aggregates
- Entrained air content
- Type and duration of curing
- Degree of hydration
- Presence of micro cracks
- Concrete surface treatments such as sealers or form oil
- Placement method, including consolidation and finishing.
- Concrete moisture condition at the time of testing.

9) Purpose

The water absorption test aims to determine the rate of water absorption by hydraulic cement concrete.

Tools and Materials

- Pan

- Support device, rods, pins, or other devices
- Top-pan balance, accurate to at least ± 0.01 g
- Timing device
- Paper towel or cloth
- Environmental chamber
- Polyethylene storage containers
- Caliper
- Sealing materials like duct tape or aluminum tape
- Plastic bag or sheeting

10) Concrete Sample Preparation

- Concrete specimens are either drilled cores or molded cylinders. They should be 100 ± 6 mm in diameter and with a length of 50 ± 3 mm.
- The test result is equal to the average test result of a minimum of two samples. The test surfaces should be at the same distance from the original exposed surface of the concrete.
- Vacuum saturate the drilled core specimens obtained from the field.
- After that, measure the mass of each test specimen to the nearest 0.01 g.
- Put test samples in the environmental chamber at a temperature of 50 ± 2 degrees and RH of 80 ± 3 % for three days.
- After that, put each specimen in a sealable container, leave a small space between the sample and container wall to allow free airflow around the specimen.
- Store the container at 23 ± 2 degrees for a minimum of 15 days at the start of the absorption test.
- Conduct the absorption procedure at 23 ± 2 degrees with tap water conditioned to the same temperature.

11) Vacuum-saturation Procedure

- Place specimen directly in vacuum desiccator. Both end faces of the sample must be exposed.
- Seal desiccator and start the vacuum pump and maintain it for three hours.
- Fill separatory funnel with the de-aerated water.
- With vacuum pump still running, open water stopcock and drain sufficient water into the container to cover the specimen.
- Close water stopcock and allow the vacuum pump to run for one additional hour.
- Close vacuum line stopcock, and then turn off the pump.
- Turn vacuum line stopcock to allow air to re-enter desiccator.
- Soak specimen underwater in the beaker for 18 ± 2 hours.

C. Water Absorption Test Procedure

- Take out specimens from the storage container and weigh them to the nearest of 0.01 g.
- Measure a minimum of four diameters of the specimen at the surface to be exposed to water and calculate the specimen's average diameter.
- Seal the side surface of specimens with suitable seal material, and seal one end that is not exposed to water with a plastic sheet that can be secured using an elastic band or other equivalent systems.
- Weigh the sealed specimen and record it as the initial mass.
- Place specimen support at the pan's bottom and pour tap water into the pan until it rises nearly 3 mm above the specimen supports, see Figure-1. This level of water in the pan needs to be maintained during the test.
- Start the timing device and put the unsealed surface of the specimen on the supports in the pan. Write the time and date of the initial contact of the sample with the water.
- Record the mass of the specimen after first contact according to the time interval provided in Table-1.
- For each record of a mass, remove the concrete specimen from the pan. Then, stop the timing device if the contact time is less than 10 minutes, and wipe out any surface water with dampened paper or cloth. Invert the specimen so that the wet surface does not contact the balance pan. Measure the mass within 15 seconds of specimen removal from the pan. Finally, place the specimen on the support in the pan and restart the timing device.

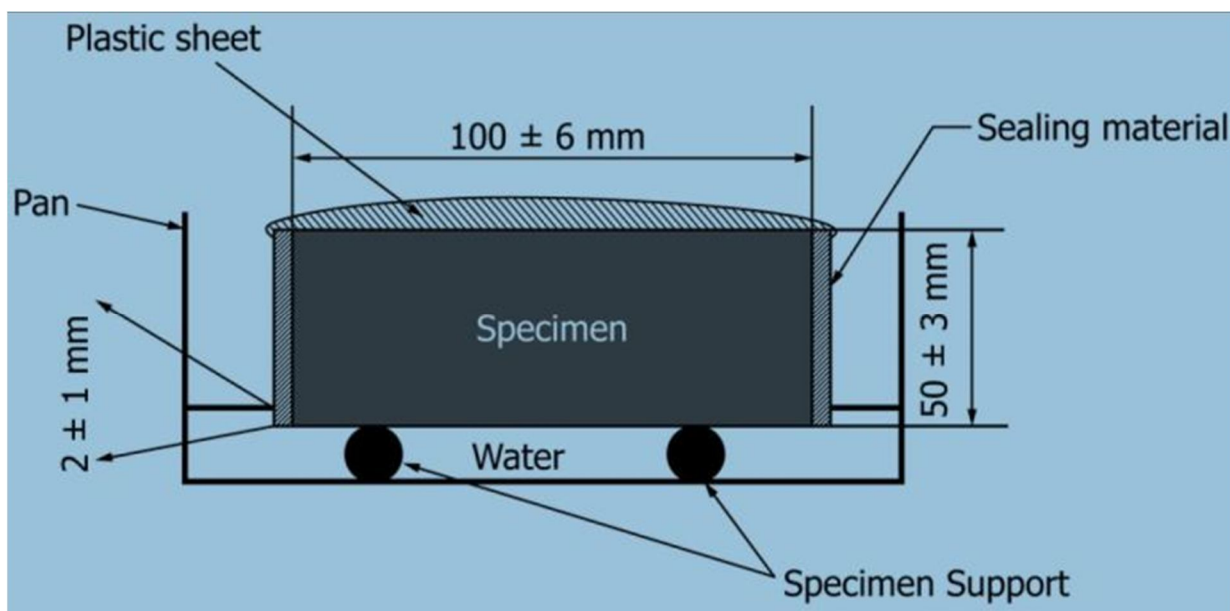

Figure-3.6: Schematic Representation of Absorption Test

Table-1: Time interval for Recording the Mass of Concrete Specimen

Time interval	Tolerances
60 second	2 second
5 minutes	10 second
10 minutes	2 minutes
20 minutes	2 minutes
30 minutes	2 minutes
60 minutes	2 minutes
Every hour up to 6 hours	5 minutes
Once a day up to 3 days	2 hours
Day 4 to 7 3 measurements 24 hours apart	2 hours
Day 7 to 9 One measurement	2 hours

1) Calculations

The following expression can be used to compute the absorption rate of concrete:

$$\text{Absorption } (I) = m_t / (a \cdot d) \text{ Equation 1}$$

Where:

m_t : the change in specimen mass in grams, at the time t ,

a : exposed area of the specimen, mm^2

d : density of the water, g/mm^3

As shown in Figure-2, the initial rate of water absorption is the slope of the line that is the best fit to I plotted against the square root of time using all the points from 1 minute to 6 hours.

The secondary rate of water absorption is the slope of the line that is the best fit to I plotted against the square root of time using all the points from

1 day to 7 days.

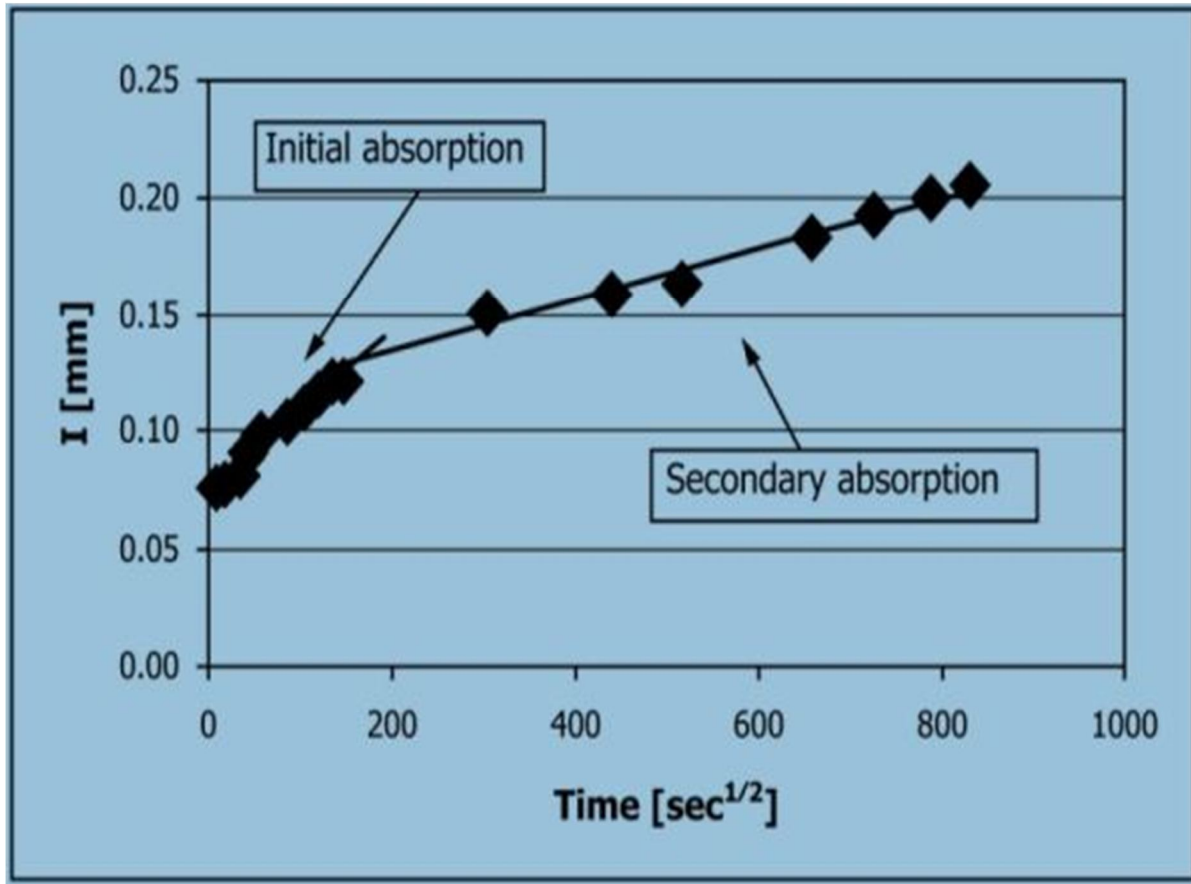

Figure-3.7: Initial Absorption rate and Secondary Absorption of Concrete

FAQs

2) What is water absorption rate test (sorptivity test) of hydraulic-cement concrete?

It is a test method by which the rate of absorption (sorptivity) of water by hydraulic cement concrete is estimated by measuring the increase of mass of the specimen resulting from absorption of water as a function of time when only one surface of the specimen is exposed to water.

3) How do you calculate the water absorption rate of concrete?

The water absorption rate of concrete is equal to the change in mass of concrete specimen divided by area of the sample exposed to water times the density of water.

4) What are the factors that influence water absorption of concrete?

1. Concrete mixture proportions
2. Entrained air
3. Moisture condition of the concrete
4. Type and duration of curing
5. Composition and physical properties of cement materials and aggregate
6. Chemical admixtures and supplementary cementitious materials in concrete
7. Concrete surface treatment like sealers
8. Presence of microcracks
9. Concrete placement method, including compaction and finishing
10. Degree of cement hydration

5) Testing the Specimen

The test procedure involves the following steps:

- The specimen with the compresso meter set up is placed over the compression testing machine platform. It is centered properly.
- The load application is performed continuously at a rate of 140 kg/cm²/minute without any obstruction.
- The load application is continued until a stress value equal to (c+5)kg/cm² is attained. Here c is the 1/3rd of average compressive strength of the cube (The strength value of cube calculated to the nearest of 5kg /cm²) which is a load of 12.4T.
- Once this stress value is reached, it is maintained for a period of 60 seconds and then reduced to the stress of 1.5 kg/cm² which is a load value of 0.3T.
- Again, the load is further increased until the stress of (c+1.5) kg/cm² is reached which is a load of 11.8T. At this point, compressometer reading is recorded.
- Now, the load is gradually reduced and the readings are recorded at 1T intervals i.e.11.8T,10.8T,9.8T,8.8T,7.8T,.....,1.8T,0.3T.
- Repeat the test by applying the load for the third time and record the compressometer's readings at an interval of 1T i.e 1.8T,10.8T,9.8T,8.8T,7.8T,.....,1.8T,0.3T is determined.



Fig:3.8-compresso meter

D. Modulus Of Elasticity

Modulus of elasticity of concrete is defined as the ratio of stress applied on the concrete to the respective strain caused. The accurate value of modulus of elasticity of concrete can be determined by conducting a laboratory test called compression test on a cylindrical concrete specimen.

In the test, the deformation of the specimen with respect to different load variation is analyzed. These observations produce Stress-Strain graph (load-deflection graph) from which the modulus of elasticity of concrete is determined. The slope of a line that is drawn in the stress-strain curve from a stress value of zero to the compressive stress value of 0.45f_c(working stress) gives the modulus of elasticity of concrete.

The laboratory test to determine the modulus of elasticity of concrete is explained below.

1) Procedure

The test procedure involves two stages. Initially, the compressometer is set-up, followed by the application of load and testing.

2) Setting Up Compressometer

A compressometer is a device used in the compression test of the concrete cylinder to determine its strain and deformation characteristics. The set up involves the following procedures.

- The compressometer consists of two frames(top and bottom), as shown in figure-1. The frames are initially assembled by the help of spacers. The spacers are held in position during the assembling.
- The pivot rod is kept on the screws which are then locked in position. The tightening screws of the top and bottom frames are kept in loose condition.
- Once the compressometer is arranged, it is placed on the concrete specimen kept on a level surface. The compressometer is centrally placed on the specimen.
- Once the position is set, the screws are tightened and the compressometer is held on the specimen.
- Once the set up is done, the spacers can be unscrewed and removed.

3) Load-Deflection Graph

From the observations, the load deflection graph is plotted for the loading conditions. Tangents are drawn at the initial portion of the graph and at the point of value equal to the working stress of the concrete mix. A line is drawn joining both points.

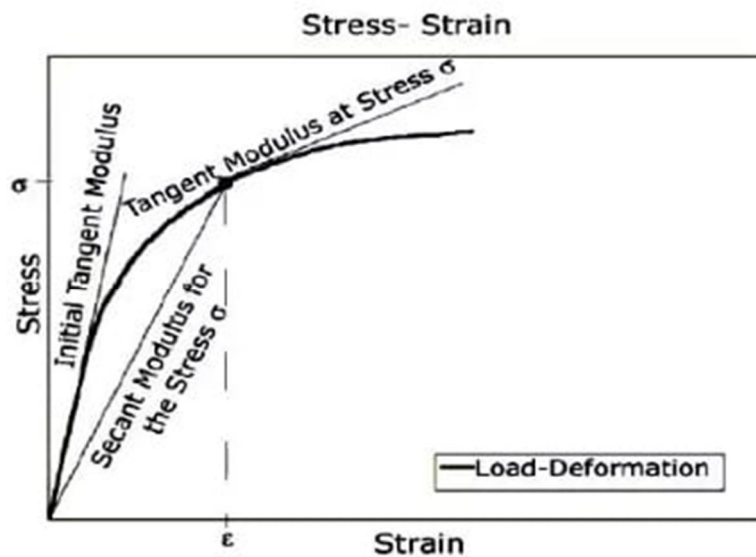

Fig.3.9.Load-Deflection Graph

4) Calculation and Results

a) Calculation

Slope of Initial Tangent gives:

$$\text{Initial tangent modulus} = \text{stress/strain}$$

Slope of tangent at working stress gives:

$$\text{Tangent modulus at working stress} = \text{stress/strain}$$

Slope of Line joining initial tangent point and point of working stress gives:

$$\text{Secant modulus} = \text{stress/strain}$$

Test Report

The following information shall be included in the report.

- Identification mark
- Date of test
- Age of specimen
- Shape and nominal dimensions of the specimen

b) Result

Initial tangent modulus of given concrete =N / mm²

Tangent modulus at working stress =N / mm²

Secant modulus (Modulus of elasticity of given concrete) = N / mm²

IV. CONCLUSION

A. General

- 1) The test results of this study indicate that there is great potential for the utilization of waste tyres in concrete mixes in several percentages, ranging from 0% to 10%.
- 2) The strength of modified concrete is reduced with an increase in the rubber content; however lower unit weight meets the criteria of light weight concrete that fulfil the strength requirements as per given in table
- 3) Concrete with high percentage of crumb rubber possess high toughness the slump of the modified concrete increases about 1.08%, with the use of 1% to 5% of crumb rubber.
- 4) Failure of plain and rubberized concrete in compression and split tension shows that rubberized concrete has higher toughness.
- 5) The split tensile strength of the concrete decreases about 30% when 20% sand is replaced by crumb rubber
- 6) The compressive strength of the concrete decreases about 37% when 20% sand is replaced by crumb rubber.

V. ACKNOWLEDGEMENT

- 1) I extend my deep sense of gratitude and indebtedness to my guide **Prof ABHIJIT MANGARAJ**, Professor, Department Of Civil Engineering, Gandhi Institute for Technology, GIFT (AUTONOMOUS) Bhubaneswar for his kind attitude, invaluable guidance, valuable suggestion, keen interest, immense help, inspiration and encouragement which helped me carrying out my project work.
- 2) I am extremely grateful to Prof SURAJIT PATTNAIK, Head of the Department of Civil Engineering and Prof ANANYA PUNYOTOYA PARIDA faculty advisor and members of Civil Engineering Department, Gandhi Institute for Technology, GIFT (AUTONOMOUS) Bhubaneswar, for providing all kind of possible help throughout the two semesters for the completion of this project work. I would like to thank to our lab technicians MR SUDARSHAN BEHERA for their kind support in execution of experiment.
- 3) It is a great pleasure for me to acknowledge and express my gratitude to my classmates, friends, my brother and parents for their understanding, unstinted support and endless encouragement during my study.
- 4) Lastly, I thank all those who are involved directly or indirectly in completion of the present project work.

REFERENCES

- [1] S.Selvakumar, R.Venkatakrishnaiah (2015), "Strength Properties of Concrete Using Crumb Rubber with Partial Replacement of Fine Aggregate", IJRASET, Vol. 4, Issue 3, March 2015.
- [2] M. Mavroulidou, J. Figueiredo (2010), "Discarded Tyre Rubber as Concrete Aggregate: A Possible Outlet for Used Tyres", Global NEST Journal, Vol 12, No 4, pp 359-367, 2010.
- [3] Eldhose C., Dr. Soosan T. G. (2014), "Studies on Scrap Tyre Added Concrete for Rigid Pavements", International Journal of Engineering Research, Volume No.3, Issue No.12, pp : 777-779, 2014.
- [4] G. Nagesh Kumar, V. Sandeep, Ch. Sudharani (2014), "Using Tyres Wastes as Aggregates in Concrete to Form Rubcrete – Mix for Engineering Applications", International Journal of Research in Engineering and Technology, Volume: 03 Issue: 11 | Nov-2014.
- [5] Siringi, Gideon M., Abolmaali, Ali Aswath, Pranesh B. (2013) "Properties of Concrete with Crumb Rubber Replacement Fine Aggregates" ASTM (American Society for Testing and materials) International, 2(1) P 5-20.
- [6] Reddy, K.S., Patil, S.k., Panday, B.B (2004) "Laboratory Evaluation of crumb Rubber Modified Asphalt Mixes" ASCE (American society of Civil Engineering), 5(2), P 7-12.
- [7] M.M Al-Tayeb& B.H. Abu Baker& H.M. Akil& H "Effect of partial replacement of sand by fine crumb rubber on impact load behavior of concrete beam: experiment and nonlinear dynamic analysis" Journal of material and structures.
- [8] Ahmed N. Bdour and Yahia A. Al-Khalayleh "Innovative Application of scrape-tire Steel Cord in Concrete Mixes" Jordan Journal of Civil Engineering, 2010.
- [9] Z. K. Khatib and F. M. Bayomy, Rubberized Portland cement concrete, Journal of Materials in Civil Engineering, 1998, 206-213.
- [10] Nadim A. Emira and Nasser S. Bajaba, The effect of rubber crumbs on some mechanical properties of concrete composites, International Journal of Mechanic Systems Engineering, 2(2), May 2012, 55-58.



10.22214/IJRASET



45.98



IMPACT FACTOR:
7.129



IMPACT FACTOR:
7.429



INTERNATIONAL JOURNAL FOR RESEARCH

IN APPLIED SCIENCE & ENGINEERING TECHNOLOGY

Call : 08813907089  (24*7 Support on Whatsapp)